

カットコアトランス・リアクトル外形図

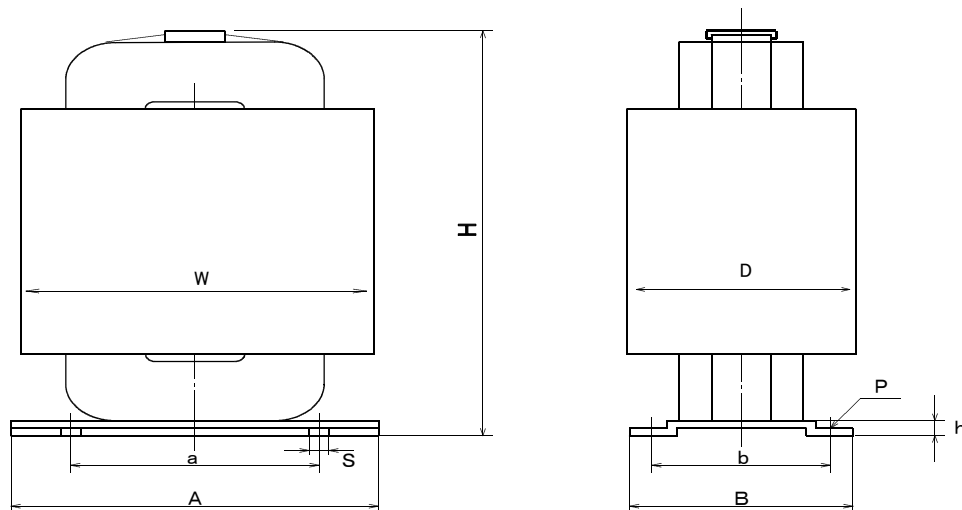

寸法 型名	A ±0.5	a ±0.5	B ±0.5	b -1.0	S ±0.2	P ±0.2	H max	h ±0.5	容量 VA	重量 kg
PTL6.3	47	30	38	28	4		70	5.0	6.3	0.35
PTL8	52	35	40	30	4		70	5.0	8	0.40
PTL10	52	35	40	30	4		80	5.0	10	0.45
PTL16A	52	35	45	35	4		80	5.0	16	0.60
PTL16B	52	35	45	35	4		90	5.0	16	0.65
PTL20	52	35	50	40	4		85	5.0	20	0.80
PTL25	59	40	45	35	4		95	5.0	25	0.90
PTL32	59	40	50	40	4		95	5.0	32	1.05
PTL40	59	40	60	45	4		100	9.0	40	1.20
PTL50	74	50	45	35	5		120	9.0	50	1.35
PTL63	74	50	55	45	5		120	9.0	63	1.60
PTL80	74	50	66	53	5		125	9.0	80	2.20
PTL100	74	50	70	60	5		125	9.0	100	2.50
PTL125	90	60	62	50	5		145	9.0	125	2.70
PTL160	90	60	70	60	5		145	9.0	160	3.05
PTL200	100	80	85	70		5.5*7	140	4.0	200	3.80
PTL250	100	80	95	80		5.5*7	145	4.0	250	4.80
PTL320	125	105	95	80		5.5*7	145	4.0	320	5.00
PTL400	125	105	110	90		6.5*9	145	4.0	400	6.50
PTL500	140	120	110	90		6.5*9	155	4.0	500	6.60
PTL630	140	120	120	100		6.5*9	155	4.0	630	8.40
PTL800A	150	130	135	115	φ9	6.5*9	170	4.0	800	10.10
PTL800B	150	130	135	115	φ9	6.5*9	190	4.0	800	13.50
PTL800C	150	130	135	115	φ9	6.5*9	180	4.0	800	12.50
PTL102	150	120	135	115	φ9		200	12.0	1000	16.00
PTL172	150	120	135	115	φ9		220	12.0	1700	19.60
PTL232	220	190	210	180	φ9		230	15.0	2300	27.00
PTL232A	220	190	210	180	φ9		250	15.0	2300	28.00
PTL382	220	190	210	180	φ9		270	15.0	3800	36.00
PTL462	220	190	210	180	φ9		280	15.0	4600	39.00

※H寸法には、引き出し線は含まれません。

PTLシリーズ外形図ver1.2

承認	作成